



PAN-LINE™ BUILDING SYSTEM

A COMPLETE GUIDE INCLUDING SPECIFICATIONS AND ACCESSORIES FOR A WIDE VARIETY OF SMALL BUILDINGS

Field Offices
Generator Buildings
Guard Houses
Relocatable Classrooms
Waste Water Treatment Buildings
HVAC Penthouses
Pump Houses
Industrial Storage Buildings
Drum Storage Buildings
Instrument Enclosures
Electrical Substations
Pipeline Measure Stations
Fire Protection Equipment Buildings
Motor Control Centers
and more!



BUTLER®

PAN-LINE™ BUILDING SYSTEM GUIDE

This manual is designed to give you the technical information necessary to specify a Panl-Line building system to meet your exact requirements. Starting with the "General Specifications" shown below, you can then add the Building and Accessory specifications needed for your building project. **This complete guide includes specifications and accessories for a multitude of building needs including:**

- Field Offices
- Guard Houses
- HVAC Penthouses
- Pump Houses
- Valve Houses
- Electric Substations
- Generator Buildings
- Relocatable Classrooms
- Waste Water Treatment Buildings
- Industrial Storage Buildings
- Motor Control Centers
- Chemical Equipment Buildings
- Drum Storage Buildings
- Instrument Enclosures
- Sound Controlled Enclosures
- Pipeline Measurement Stations
- Fire Protection Equipment Buildings
- Microwave Stations

If your building requires features not shown in this manual, please contact our Panl-Line Specialist at 304-586-0979.

GENERAL SPECIFICATIONS

1. General

- 1.1 Each building shall be supplied with all necessary component parts, including foundation anchors, to form a complete building system. All parts shall be new and free from defects.
- 1.2 The building width and length shall be measured from the outside of the building wall panels and the height of the building shall be the distance measured from the bottom surface of the base channel to the exterior juncture of the roof and sidewall panels.
- 1.3 The building supplier shall furnish a complete set of building erection drawings, illustrating the step-by-step sequence for the erection of the building. The erection drawings shall be prepared specifically for the building covered by these specifications, showing the exact location for all roof and wall accessories and all anchor bolt locations.

2. Design Criteria

- 2.1 All buildings shall be designed in accordance with the applicable sections of the 2010 edition of the North American Specification for the Design of Cold-Formed Steel Structural Members. Structural members shall be designed in accordance with the 14th edition of the American Institute of Steel Construction "Manual of Steel Construction, Allowable Stress Design."

3. Roof Panel Design

- 3.1 Roof panels shall be supplied in a single continuous length from eave line to eave line and shall be designed to tightly interlock so that no fasteners are required at intermediate points along the panel side laps. Roof panels shall be a maximum of 16" wide with a flat surface between the interlocking side ribs. The interlocking ribs shall be a minimum 3" high, and shall be turned upward.
- 3.2 Roof panels shall be nominal 24-gauge steel coated on both sides with a Galvalume® coating of corrosion resistant aluminum-zinc alloy applied by a continuous hot dipping process (ASTM A 792). Coating weight shall be a minimum of 0.55 oz. of aluminum-zinc alloy per square foot of coated sheet (both sides) – equivalent to nominal 0.80 mil thickness on each side. Minimum yield strength of panel material shall be 50,000 psi (345 MPa).

4. Wall Panel Design

- 4.1 Exterior wall panels of the building shall be a single continuous length from the base channel to the roof line of the building at the sidewalls and endwalls of the building, except where interrupted by wall openings. Wall panels shall be 16" wide with a 3" deep inward turned interlocking side rib. Panels shall contain two 3/4" deep by 3 1/8" wide fluted recesses, each starting 2 7/16" from each panel edge. Wall panels shall be fastened internally at the base and eave of the building with 3/8" diameter electro-galvanized machine bolts placed within the panel interlock. The fastening system shall be designed so that no wall fasteners are exposed on the exterior surfaces of the wall.
- 4.2 Wall panels shall be nominal 24-gauge galvanized steel conforming to ASTM A 653 with a galvanized coating conforming to G90 (.9 oz.) standards. Minimum yield strength of panel material shall be 50,000 psi (345MPa). Panel material shall be embossed with a random pattern pebble embossure of approximately .007" — .008" depth.
- 4.3 The bottom of the wall panels shall be closed off with polystyrene closures conforming to the panel profile.

5. Wall Panel Finish Coating

- 5.1 All exterior surfaces of the galvanized steel wall covering and exterior trim will receive a factory, roller applied paint coating having an exterior coating thickness of 0.95 to 1.1 mils of dry film thickness. The finish coat for wall panels will be a siliconized polyester formulation. CERAM-A-STAR 1050 is one component of the total paint system. When applied in accordance to specifications the following field performance can be expected.

	Walls	Roof
Film Integrity	30 years	30 years
Chalk	No more than #8 for 30 years	No more than #6 for 30 years
Fade	No more than 5ΔE Hunter units for 30 years	No more than 7ΔE Hunter units for 30 years

- 5.2 The exterior wall color shall be (SELECT ONE) Arctic White, Desert Tan, Laurel Green, Roman Bronze, Shell Grey or Twilight Blue.

PAN-LINE™ COMMENTARY AND SPECIFICATIONS

DESIGN COMMENTARY

Panl-Line buildings are designed in accordance with nationally-recognized building codes including: National Building Code of Canada (NBCC), International Building Code and state or local Building codes as applicable by ordinance.

To allow us to furnish a building system to meet your specific needs, please specify:

1. – Applicable Building Code including year.
2. – The roof live load in pounds per square foot (PSF).
3. – The ground snow load in pounds per square foot (PSF) with exposure coefficient and applicable drifting information.
4. – The wind load in miles per hour (MPH) with exposure coefficient.
5. – Collateral loads in pounds per square foot (PSF) or cable tray loads in PLF (including layout).

DESIGN SPECIFICATIONS

6. Design Code and Loads

6.1 The building shall be designed in accordance with the (SPECIFY CODE & EDITION) and the following loads in addition to the weight of the building:

- A. The roof live load of the building shall be (specify) pounds per square foot applied to the horizontal projection of the building.
- B. The roof snow load (based on a (SPECIFY) pounds per square foot ground snow load) shall be applied to the horizontal projection of the building.
- C. The wind load shall be (SPECIFY) miles per hour. The design wind load exposure coefficient shall be (SELECT "B," "C" or "D").
- D. Where the NBCC code governs, all live loads, snow loads, and wind loads "q", (1:10) and (1:30), shall be (SPECIFY) in kilopascals (kPa).

6.2 All combining and distributing of auxiliary equipment loads imposed on the building system shall be done in accordance with the applicable Building Code.

PANEL DIMENSIONAL DATA

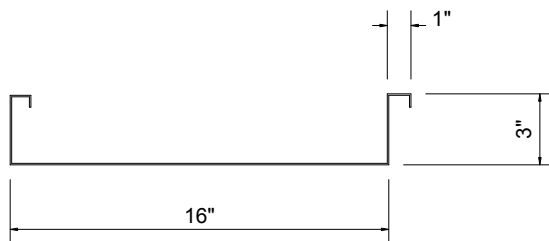

ROOF PANEL

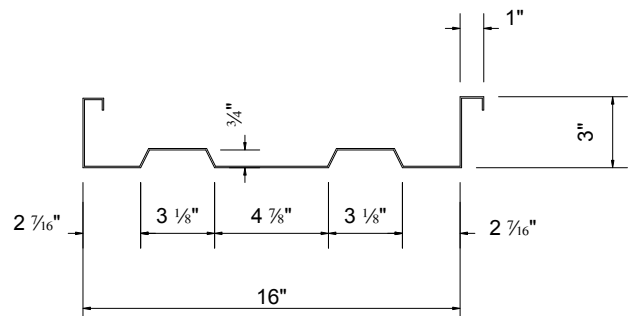

WALL PANEL

PAN-LINE™ 1 BUILDING SYSTEM & SPECIFICATIONS

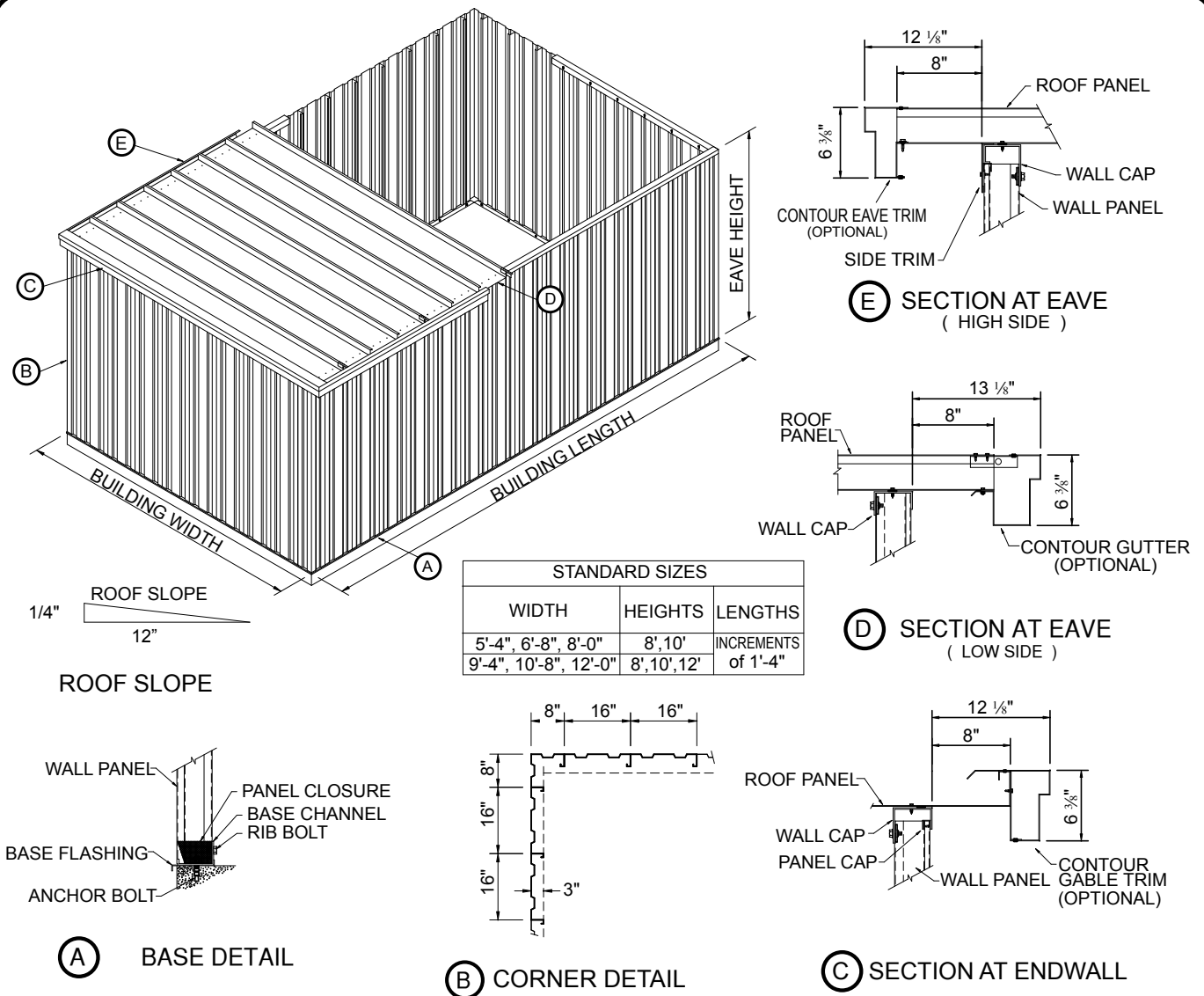

PAN-LINE 1 SPECIFICATIONS

7. Building System

- 7.1 The building shall be a self framing design utilizing the roof and wall panels as the primary structural supporting components.
- 7.2 The transmission of horizontal wind loads shall be made through the interlocking panel roof system and no separate roof or wall diagonal bracing will be permitted.
- 7.3 Wind bent framing shall be provided where required for proper transmission of lateral wind loads. Wind bents shall be minimum 8" deep cold formed galvanized steel "C" sections.
- 7.4 The building roof shall rise 1/4" to 12".
- 7.5 The roof panels shall extend a minimum of 8" over the walls of the basic building.
- 7.6 (Optional) Contour Gable Trim at each endwall and high side Eave Trim shall be provided. Trim shall be 26-gauge galvanized steel factory finished in (SELECT ONE) Arctic White or Roman Bronze.
- 7.7 (Optional), (select either Gutter or Eave Trim) Contour Gutter shall be provided at the low side eave. Gutter shall be 26-gauge galvanized steel in the same finished and color as the Contour Gable Trim. (Quantity) Downspouts of the same color as the Gutter shall be provided.
or
Contour Eave Trim shall be provided at the low side eave. Trim shall be 26-gauge galvanized steel in the same finish and color as the Contour Gable Trim.

PAN-LINE™ 2 SPECIFICATIONS

Pan-Line 2 buildings up to 24' in length do not require intermediate structural frames and the "Self Framing" specification should be used for these lengths. Over 24' long buildings require structural frames on 12', 16' 20', or 24' spacing and the "Structural Framed" specification should be used for all buildings over 24' long.

7. Building System (Self Framing)

- 7.1 The building shall utilize the structural strength of the interlocking wall system to support the building vertical live load and wind loads and shall not require column, rafter or wall girt supporting members.
- 7.2 The roof panels of the building shall be supported by nominal 12-gauge by 10" deep galvanized steel "C" purlins spaced on maximum 5'-0" centers. Purlins shall be supported at the endwalls of the building by a pre punched nominal 14-gauge galvanized steel "Z" rake girt.
- 7.3 The transmission of horizontal wind loads shall be made through the interlocking panel roof system and no separate roof or wall diagonal bracing will be permitted.
- 7.4 The building roof line shall be a "double slope" type with a maximum roof rise of 1/3" to 12".
- 7.5 Contour gable trim shall be provided at the endwalls of the building. Trim shall be nominal 26-gauge galvanized steel, factory finished in (SELECT ONE) Arctic White or Roman Bronze.
- 7.6 (Optional, select either Gutter or Eave Trim.)
Contour Gutter shall be provided at the eave lines of the building. Gutter shall be nominal 26-gauge galvanized steel in the same finish and color as the Contour Gable Trim. (Quantity) Downspouts of the same color as the gutter shall be provided at each eave line.
- OR Contour Eave Trim shall be provided at the eave lines of the building. Trim shall be nominal 26-gauge galvanized steel in the same finish and color as the Contour Gable Trim.

7. Building System (Structural Framed)

- 7.1 The building shall utilize the interlocking wall panels as the primary endwall structural support and shall utilize clear span structural frames as the main intermediate supporting members. Primary sidewall structural support will be provided solely by the building sidewall panels.
- 7.2 The roof panels of the building shall be supported by nominal 12-gauge by 10" deep galvanized steel "C" purlins spaced on maximum 5'-0" centers. Purlins shall be supported at the endwalls of the building by a prepunched nominal 14-gauge galvanized steel "Z" rake girt.
- 7.3 Purlins shall be of single span design connected to the intermediate structural frames by means of a minimum 1/4" thick clip. Purlins shall extend a minimum of 4" above the top flange of the intermediate structural frames.
- 7.4 No intermediate wall girts shall be permitted in the building.
- 7.5 The transmission of the horizontal wind loads shall be made through the interlocking panel roof system and no separate roof or wall diagonal bracing will be permitted.
- 7.6 Intermediate structural frames shall consist of either hot rolled W sections or welded plate parallel flange columns and either hot rolled W section girder or a single piece welded plate tapered girder. Frames shall be cleaned and factory primed with a minimum of one shop coat of gray primer. Anchors are to be supplied by others.
- 7.7 Frames shall be factory punched for attachment of anchor bolts, eave struts and purlin clips. All bolts for frame assembly shall be high strength per ASTM A-325 standards.
- 7.8 The building roof line shall be a "double slope" type with a maximum roof rise of 1/3" to 12".
- 7.9 Contour gable trim shall be provided at the endwalls of the building. Trim shall be nominal 26-gauge galvanized steel, factory finished in (SELECT ONE) Arctic White or Roman Bronze.
- 7.10 (Optional, select either Gutter or Eave Trim.)
Contour Gutter shall be provided at the eave lines of the building. Gutter shall be nominal 26-gauge galvanized steel in the same finish and color as the Contour Gable Trim. (Quantity) Downspouts of the same color as the gutter shall be provided at each eave line. OR Contour Eave Trim shall be provided at the eave lines of the building. Trim shall be nominal 26-gauge galvanized steel in the same finish and color as the Contour Gable Trim.

PAN-LINE™ 2 BUILDING SYSTEM

SELF-FRAMING BUILDING (ONE BAY ONLY)

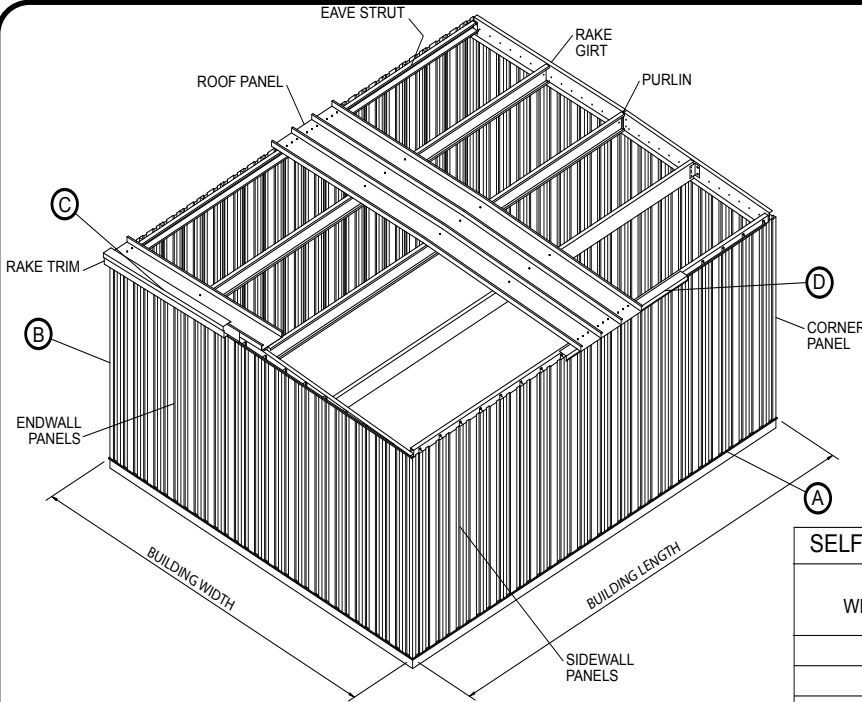

SELF FRAMING-STANDARD SIZES-ONE BAY ONLY

WIDTH	HEIGHTS	LENGTHS
12'	8', 10', 12', 14'	12', 16', 20', 24'
16'	8', 10', 12', 14'	12', 16', 20', 24'
20'	8', 10', 12', 14'	12', 16', 20', 24'
24'	8', 10', 12', 14'	12', 16', 20', 24'
28'	8', 10', 12', 14'	12', 16', 20', 24'
32'	8', 10', 12', 14'	12', 16', 20', 24'

SELF-FRAMING BUILDING (MULTIPLE BAY)

FRAMED STANDARD SIZES		
WIDTH	HEIGHTS	LENGTHS
12'	9', 10', 12', 14'	12' PLUS INCREMENTS OF 4'-0"
16'	9', 10', 12', 14'	
20'	9', 10', 12', 14'	
24'	10', 12', 14'	
28'	10', 12', 14'	
32'	10', 12', 14'	

NOTE:
Any combination of 12', 16', 20', and 24' bays can be used to make up building length.

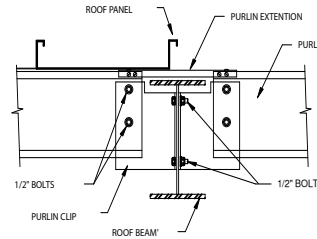
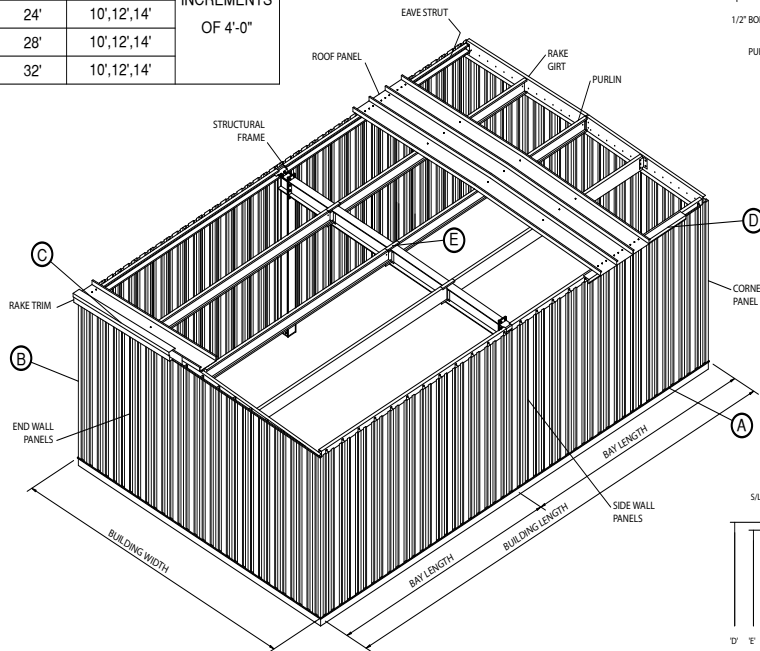

(E) PURLIN TO FRAME DETAIL

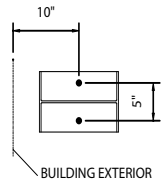

BASE PLATE DETAIL

WIDTH DIMENSIONS		HEIGHT DIMENSIONS		
BLDG. WIDTH 'A'	WIDTH BETWEEN COLUMNS 'B'	BLDG. EXTERIOR EAVE HEIGHT 'D'	INTERIOR CL. HT. @ EAVE STRUT 'E'	INTERIOR CLEAR HEIGHT @ FRAME 'F'
12'	9'-8"	9'-0"	8'-8"	7'-8 1/4"
16'	13'-8"	10'-0"	9'-8"	8'-8 1/4"
20'	17'-8"	12'-0"	11'-8"	10'-8 1/4"
24'	21'-8"	14'-0"	13'-8"	12'-8 1/4"

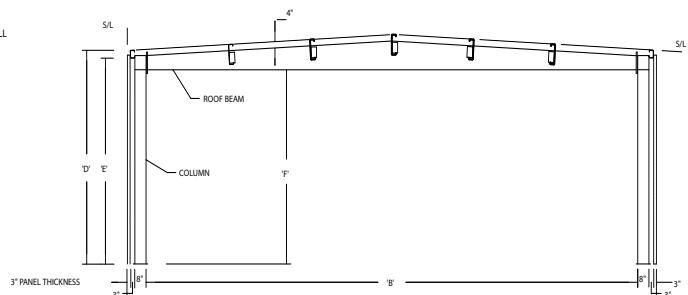

PAN-LINE™ 2 BUILDING SYSTEM

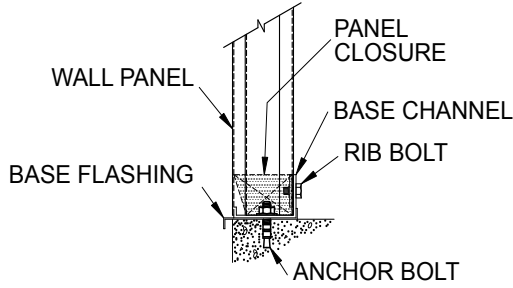

(A) BASE DETAIL

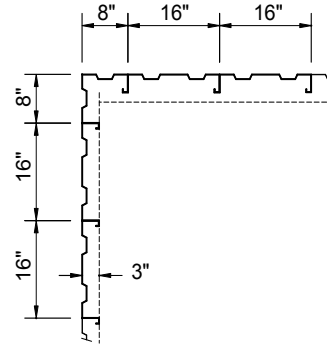

(B) CORNER DETAIL

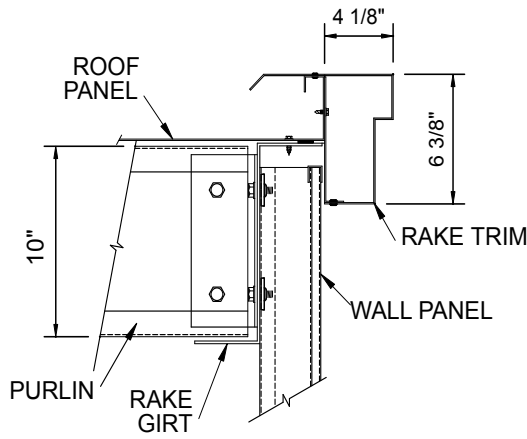

(C) SECTION AT ENDWALL

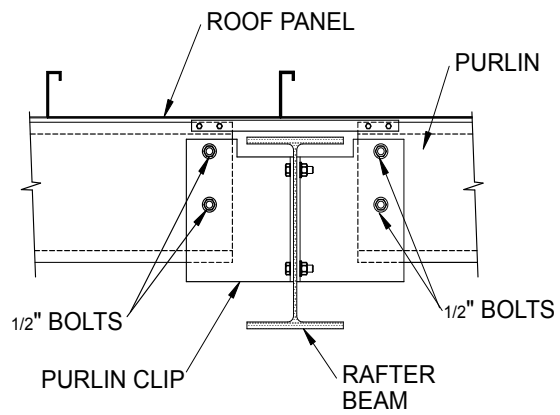

(E) PURLIN TO FRAME DETAIL

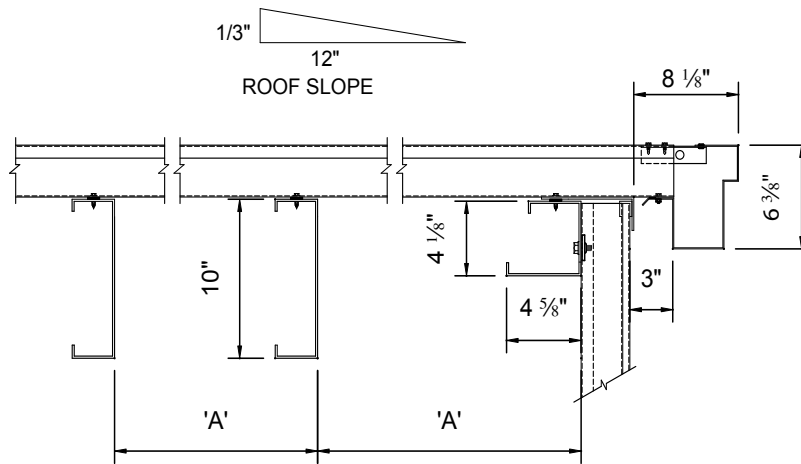

(D) SECTION AT EAVE

PURLIN SPACING			
BLDG. WIDTH	'A'	BLDG. WIDTH	'A'
12'	2'-10 1/2"	24'	3'-11"
16'	3'-10 1/2"	28'	4'-7"
20'	4'-10 1/2"	32'	3'-11 1/4"

PANL-LINE™ HOLLOW METAL DOORS

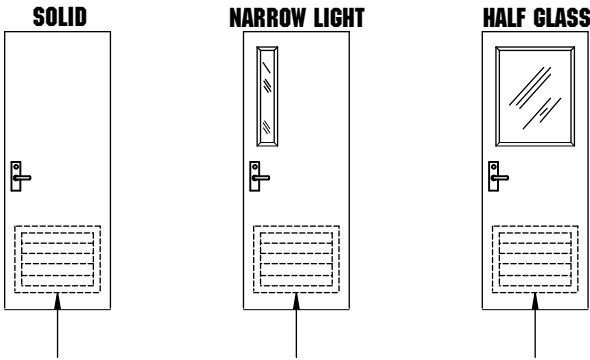

Louver, 22" Wide x 20" High (Optional)

Door Size	Glass Size	
	Narrow Light	Half Glass
2'-4" x 7'-0"	6 5/8" x 29 5/8"	11 3/4" x 29 5/8"
3'-0" x 7'-0"	6 5/8" x 29 5/8"	24" x 30"
3'-8" x 7'-0"	6 5/8" x 29 5/8"	24" x 30"
* 6'-0" x 7'-0"	6 5/8" x 29 5/8"	24" x 30"

* INDICATES DOUBLE LEAF

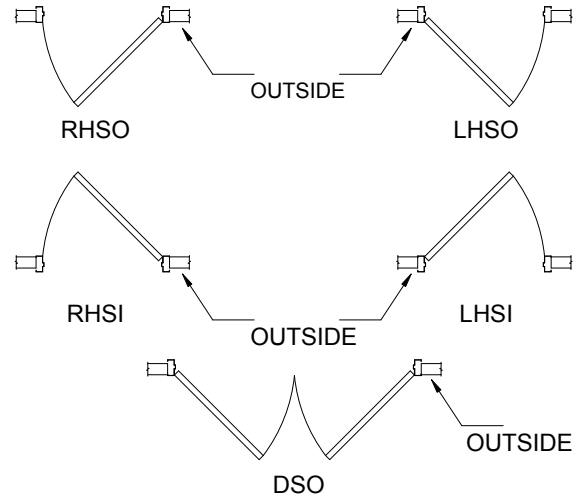

DOOR SWING OPTIONS

NOTE: If swing is not specified RHSO will be furnished.

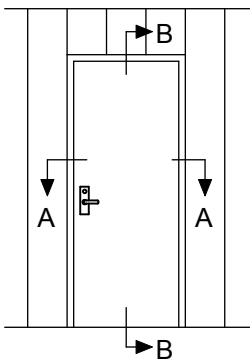

SINGLE DOOR ELEVATION

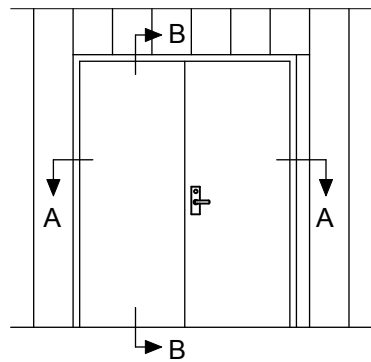

DOUBLE DOOR ELEVATION

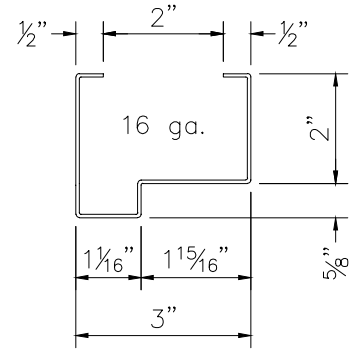

SECTION @ FRAME

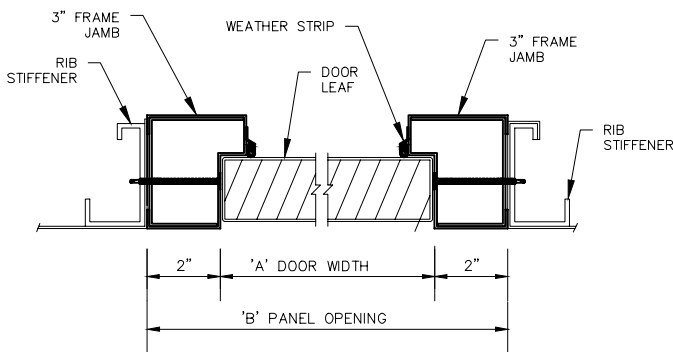

SECTION 'A'

DOOR WIDTH 'A'	OPEN WIDTH 'B'
2'-4"	2'-8"
3'-0"	3'-4"
3'-8"	4'-0"
6'-0"	6'-4"

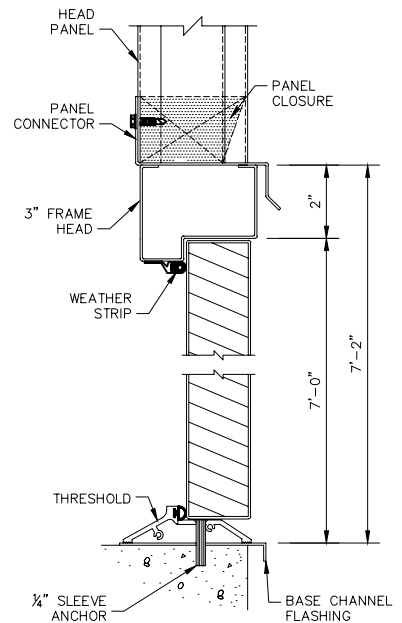

SECTION 'B'

PAN-LINE™ PERSONNEL DOOR SPECIFICATIONS

PERSONNEL DOOR SPECIFICATIONS

Door shall be 1–3/4" thick full flush type. Door panels shall be nominal 18–gauge galvanized steel welded to nominal 16–gauge flush–mounted end channels. The door shall be manufactured in accordance with ANSI/SDI 100, Grade 1, Model 1 Level C.

Door leaf core shall be foamed in place polyurethane foam conforming to ASTM–D 1621 and chemically bonded to the door panels. Calculated U value of the door leaf shall be 0.07 (R=14.3), and sound transmission shall be STC 26 per ASTM E90–61T C236 tests.

Door frames shall be 3" deep single rabbeted type of nominal 16–gauge galvanized steel.

Door and frames shall be painted with one coat of a specified finish. All doors shall be provided "assembled in their frames with all hardware, except door knobs, installed on the leaf."

Standard door hardware shall consist of:

Mortise cylinder lockset per ANSI A156.13, Series 100 Grade 1, Function F13, 626 satin chrome finish.

4–1/2" x 4–1/2", STD. WT., plain bearing, hinges per ANSI A5133, 630 satin stainless steel finish with nonrising pins (3 per door leaf).

5" wide x 7/8" high extruded aluminum threshold with vinyl weather–stripping.

1/4" x 11/16" aluminum/vinyl weatherstripping.

Door type shall be (SELECT ONE) Solid, Narrow Light, Half Glass. (If Narrow Light or Half Glass add:) Door shall be factory glazed with (SELECT ONE) 1/4" acrylic, 1/4" polycarbonate, 1/4" reinforced wire glass.

DOOR HARDWARE OPTIONS:

- A. Replaces Mortise Lockset
1. Standard duty cylindrical key in–knob per ANSI A 156.2, Series 4000, Grade 2, Function F81, 630 satin stainless steel finish (Not recommended for 3870 Doors).
- B. Replaces Mortise Lockset (SELECT ONE)
1. Rim type "Cross Bar," UL listed panic device per ANSI A 156.3, Type 1, Grade 1, Function 05 with 630 brushed stainless finish.
 2. Rim type "Push Pad," UL listed panic device per ANSI A 156.3, Type 1, Grade 1, Function 08 with 689 aluminum lacquer interior finish and 626 satin chrome exterior finish (Not available on 2470 door).
- NOTE: Double swing doors with rim type exit devices should specify (SELECT ONE):
- A) One leaf active (overlapping astragal – no center mullion).
 - B) Both leafs active (removable center mullion).
- C. Replaces Plain Bearing Hinges
1. 4–1/2" x 4–1/2" STD. WT., ball bearing hinge per ANSI A 5113, 630 satin stainless finish with nonrising pins (3 per door leaf).
- D. Additions to Door Hardware
1. Door closer, surface applied, per ANSI A 156.4, Grade 1, with a 689 aluminum lacquer finish. (Ball bearing hinges are recommended with closers).
 2. Louver, adjustable blade louver with mesh screen operated by interior thumb lever. Louver shall be factory installed in the door leaf.

PAN-LINE™ WALL ACCESSORIES

OVERHEAD DOOR OPENINGS

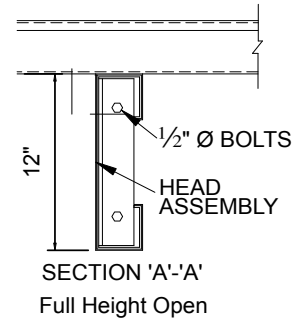
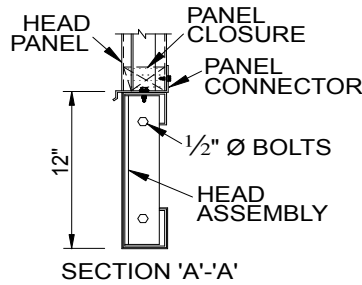
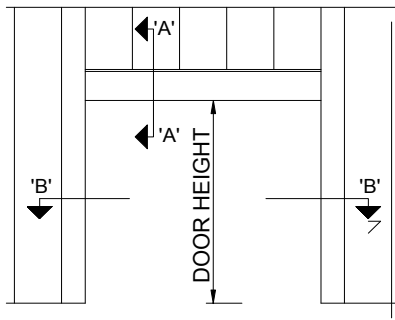

NOTE: BE SURE TO CHECK HEADROOM REQUIRED FOR DOOR BEING USED IN THE OPENING !

Framed openings shall be 12 gauge, high strength galvanized steel. The jambs and head shall provide a minimum 2-1/2" wide inside surface for field mounting of door track hardware. Head and jamb covers shall be provided of 24 gauge galvanized steel prefinished same color and finish as wall panel.

Door Width	Door Height
8'-0"	1'-0" INCREMENTS STARTING 1'-0" BELOW EAVE HEIGHT.
10'-8"	
12'-0"	
14'-8"	
16'-0"	

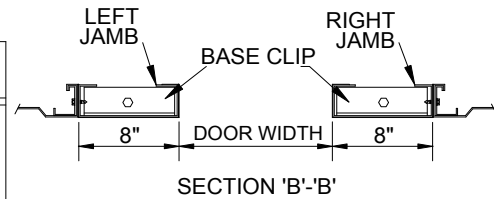

SPECIAL WALL OPENINGS

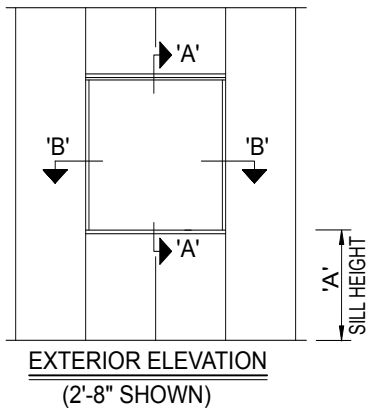

NOTE: Customer to specify dimensions 'A' and 'B'

The building manufacturer shall supply all necessary framing and connections to structurally replace the panels removed by any wall opening.

The supplier of the equipment being placed in the opening shall be responsible for all trim required to make the installed equipment weathertight.

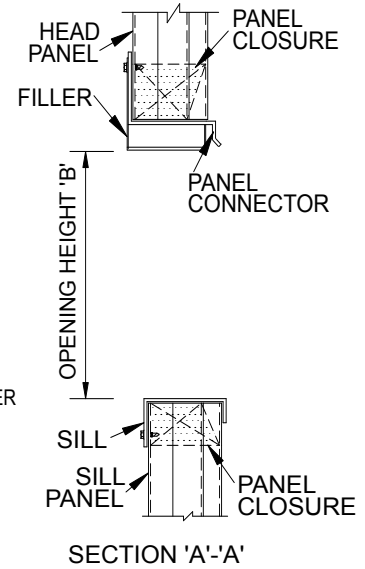
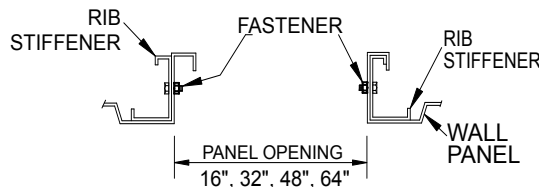

ADJUSTABLE WALL LOUVERS

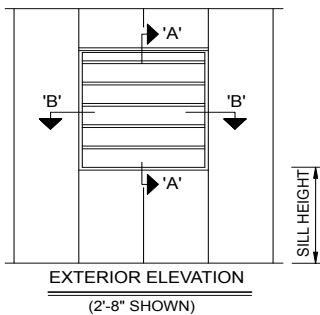

Louver Sizes		Free Area
WIDTH 'A'	HEIGHT 'B'	
16"	24"	1.3 Sq. Ft.
32"	24"	2.8 Sq. Ft.
48"	42"	8.1 Sq. Ft.

NOTE: Customer must specify louver sill height. Minimum sill or head height is 6".

Adjustable louvers shall be general purpose type of self framing design. The louver frame shall be of nominal 14-gauge formed aluminum and the louver blades shall be nominal 12-gauge extruded aluminum. Finish shall be natural mill.

Blades shall be pivoted on 1/2" diameter aluminum pivot pins through nylon flanged bearings and operated by means of a pull bar operating handle. All louvers shall be complete with an exterior mounted 18"-14" aluminum mesh insect screen.

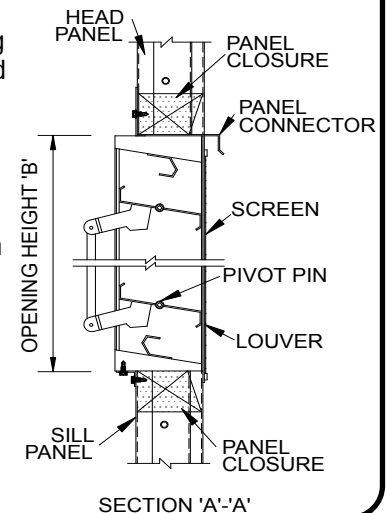
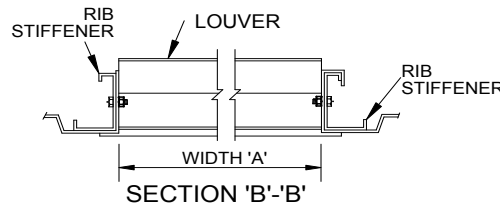

PAN-LINE™ WINDOWS

HORIZONTAL SLIDING WINDOWS

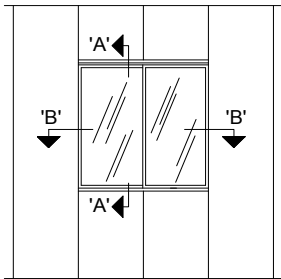

EXTERIOR ELEVATION
(2'-8" SHOWN)

Window Sizes		Standard Sill Height If Not Specified
Width 'A'	Height 'B'	
32"	36"	4'-2 5/8"
48"	36"	4'-2 5/8"
48"	48"	3'-2 5/8"

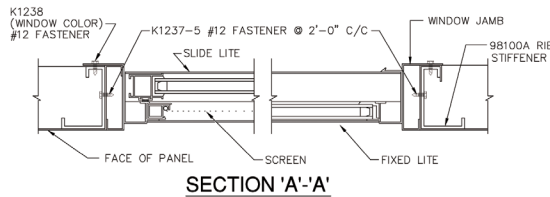

SECTION 'A'-A'

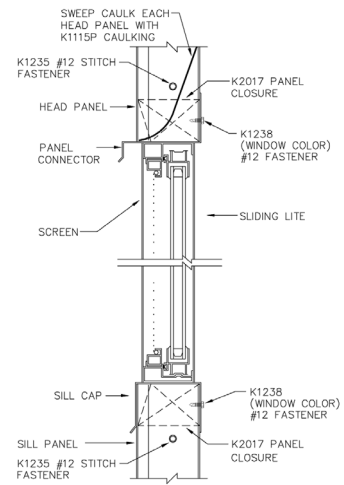

SECTION 'B'-B'

Sliding Windows

Windows shall meet or exceed ANSI/AAMA 101 and AAMA 1302.5 standards. All window framing sections shall be made of 6063-T5 extruded aluminum color finished in (WHITE, BRONZE) (SELECT ONE) factory baked enamel. Windows shall be factory assembled and factory glazed with 5/8" clear insulated glass.

FIXED WINDOWS

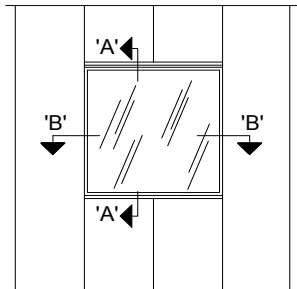

EXTERIOR ELEVATION
(2'-8" SHOWN)

Window Sizes		Standard Sill Height If Not Specified
Width 'A'	Height 'B'	
32"	36"	4'-2 5/8"
48"	36"	4'-2 5/8"
48"	48"	3'-2 5/8"

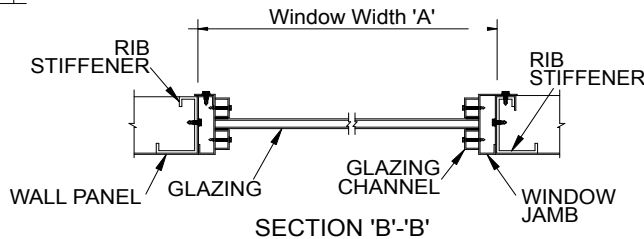

SECTION 'B'-B'

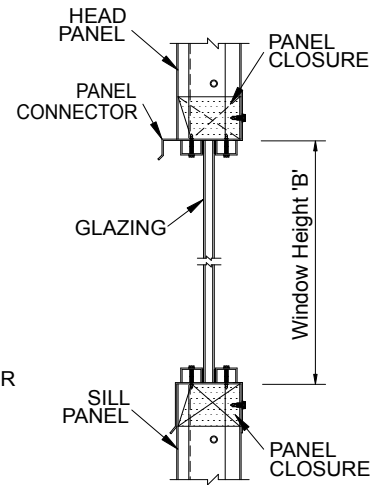

SECTION 'A'-A'

Fixed Windows

Fixed Windows shall be furnished factory glazed and complete with all attaching hardware. The window unit shall be factory assembled for single unit installation. All window sash sections shall be formed from nominal 18-gauge galvanized G90 steel and finished in (WHITE, BRONZE) (SELECT ONE) factory baked enamel. Windows shall be factory glazed with (SELECT ONE FROM LIST BELOW).

- 5/8" clear insulated glass
- 1/4" clear polished wire glass
- 1/4" clear acrylic
- 1/4" polycarbonate
- 1/4" obscure glass

PAN-LINE™ ROOF VENTS / CURBS

TURBINE VENTILATOR

Turbine ventilator shall be 12" diameter capable of exhausting 580 CFM of air at a 5 MPH wind velocity. Ventilators shall be made of galvanized steel with aluminum external bracing. Upper rotary bearings shall be bronze oilless and lower bearings shall be thrust type ball bearings.

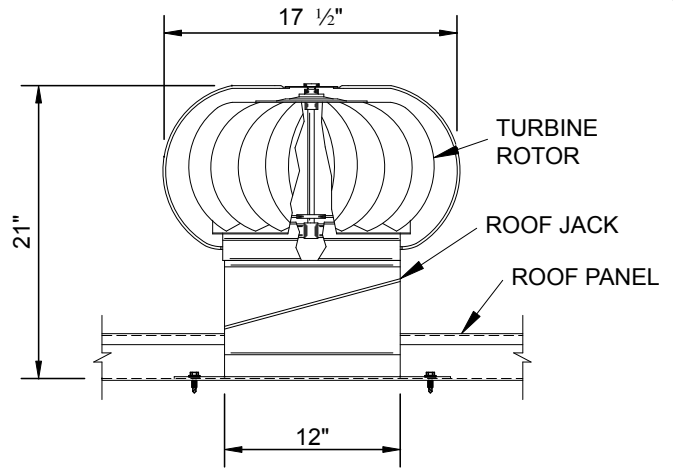

STATIONARY VENTILATOR

Stationary ventilator shall be 12" diameter capable of exhausting 495 CFM of air with a 20 degree F temperature differential, 10 MPH wind velocity and a 10' ventilator height.

Ventilators shall be fabricated from industrial grade aluminum and shall include bird screening and chain operated dampers.

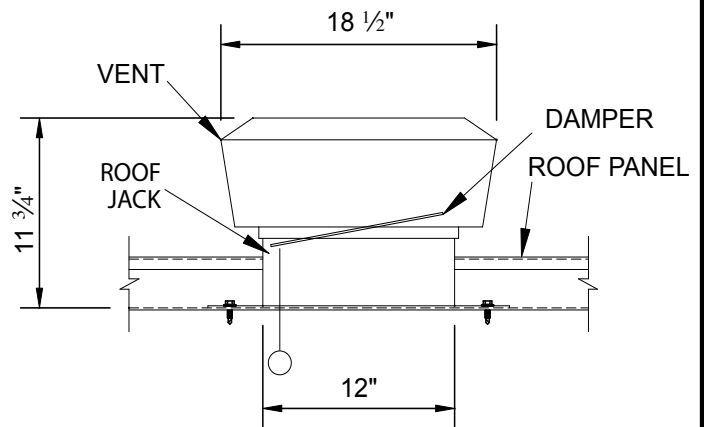

POWER ROOF VENTILATOR

Power roof ventilator shall be 12" in diameter and capable of 370 CFM air movement at .06 static pressure. Ventilator shall be equipped with an adjustable thermostat. Power requirement shall be 1 amp at 115 volts.

An intake louver of 115 square inches free air area shall be provided for each ventilator.

Note: Not C.S.A. approved for Canada

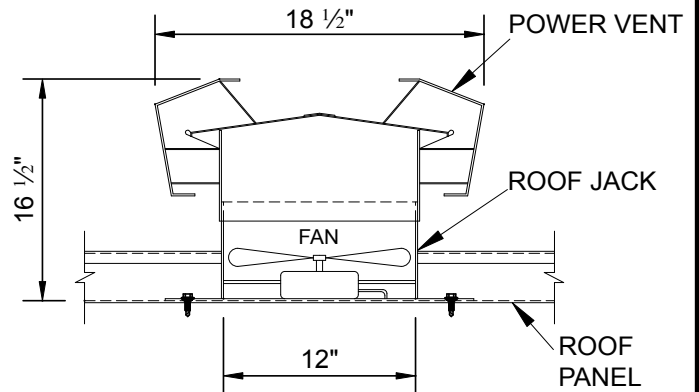

ROOF CURBS

Roof curbs shall be fabricated of nominal 16-gauge Galvalume steel with welded mitered corners and insulated with 1-1/2" thick, 3# density fiberglass. The curb shall be provided with all necessary components to form a weathertight seal between the base of the roof curb and the roof panels. The curb support ledge shall be a minimum of 4" above the rib of the roof panel.

CURB SIZES	
WIDTH "A"	LENGTH "B"
SPECIFY	SPECIFY

NOTE: Inside clear dimensions are 3" less than 'A' and 'B' dimensions.

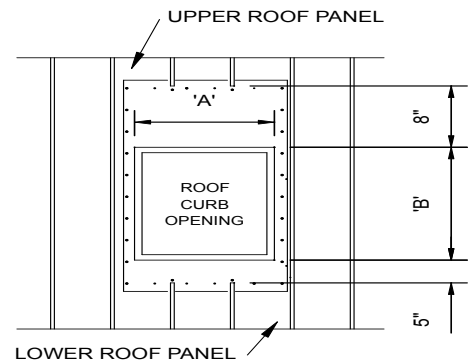

PAN-LINE™ INSULATION AND CEILING

FIBERGLASS ROOF INSULATION

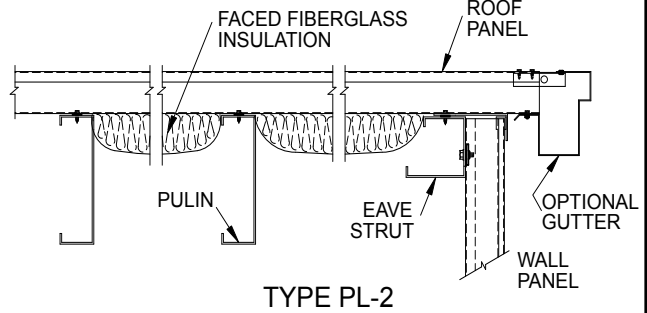
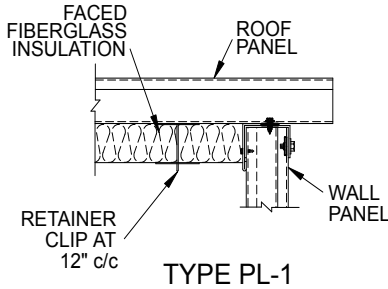

Roof insulation shall consist of 48" wide fiberglass faced on its exposed side with a white metalized polypropylene scrimkraft facing. The faced insulation material shall have a UL Flame Spread Rating of 25 or less when tested in accordance UL723 or ASTM E-84 procedures.

The "U" value through the insulated roof shall be (SELECT ONE FROM CHART 'A') BTUs per square foot when measured in accordance with the "Zone Method" contained in ASHRAE "Handbook of Fundamentals" 1981 edition.

SYSTEM VALUES		R
3"	Continuous	10.4

Calculated system "U" value 0.10, 0.08 & 0.05 respectively (ASHRAE zone methods)

NOTE: For condensation control only. Not intended for buildings that are heated or cooled

CEILING SYSTEM

The metal ceiling system shall consist of 16" wide interlocking panels of minimum 24-gauge embossed galvanized steel factory painted White. The ceiling system shall be supported at its perimeter by concealed angles and hook bolts and shall be furnished complete with all necessary connectors and fasteners.

The ceiling shall be insulated with 16" wide by 3-1/2" thick unfaced fiberglass insulation laid at right angles to the panel ribs. The "R" value through the finished ceiling shall be a maximum of (SELECT ONE FROM CHART 'A') BTUs per square foot when measured in accordance with the "Zone Method" contained in ASHRAE "Handbook of Fundamentals", 1981 Edition.

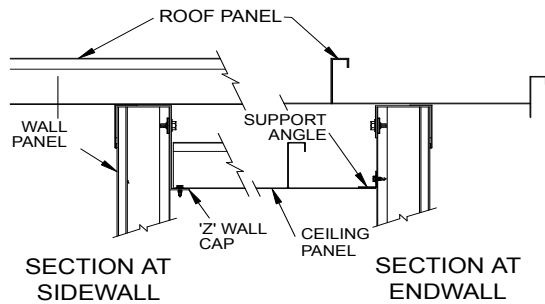

Cavity Insulation	R 13
Continuous Insulation	R 13

Calculated system "U" value 0.06 (ASHRAE zone method)
* INDICATES 3" PARALLEL AND 3" PERPENDICULAR TO PANEL RIBS

PAN-LINE™ 1 INTERIOR WALL LINERS

FORMED WALL LINER

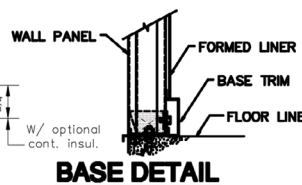
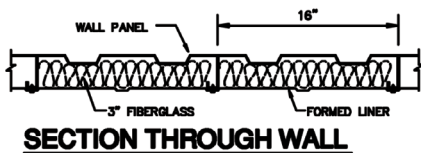

The interior of the metal walls shall be lined with nominal 26-gauge galvanized steel panels factory finished white. Panels shall be 32" wide by 1/4" deep ribs on 8" centers.

Liner insulation shall be 3-1/2" thick unfaced fiberglass.

(Optional) The liner shall have 1/8" diameter perforations on 3/8" staggered centers. The assembled wall system shall have a tested NRC of 0.90 and STC of 29.

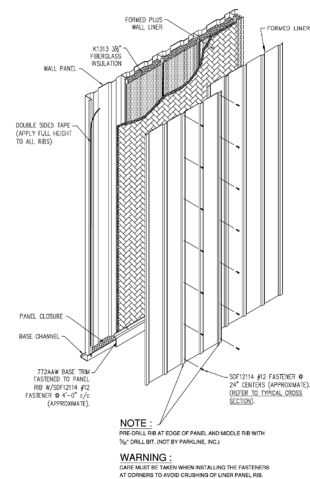

Continuous Insulation	R 7.5
Cavity Insulation	R 13

Calculated system "U" value 0.16 (ASHRAE zone method)

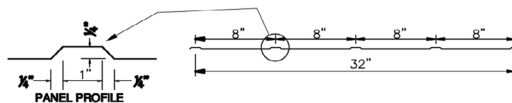

PAN-LINE™ INTERIOR FINISHES

A48 ACOUSTICAL WALL SYSTEM

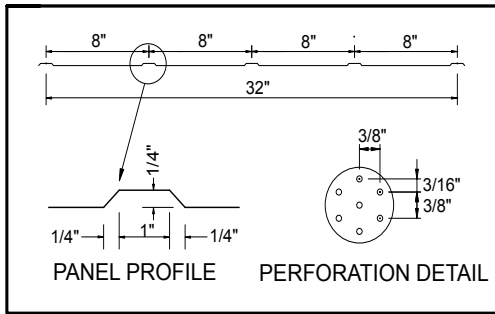

This System has NOT been sound tested

Cavity Insulation	R 13
Continuous Insulation	R 0.45
Cavity Insulation	R 13

Calculated system "U" value 0.07 (ASHRAE zone method)

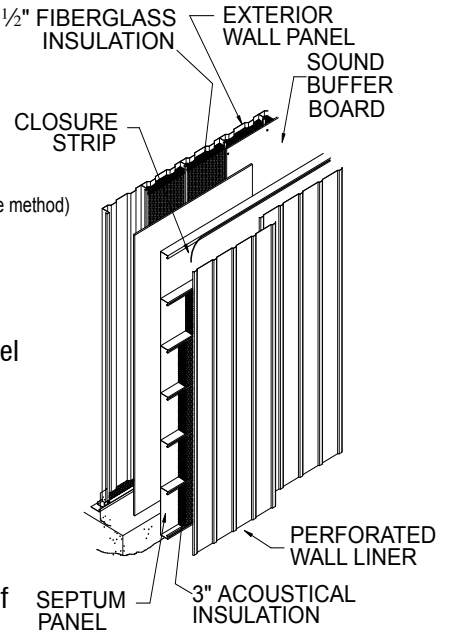

A48 Acoustical Wall System consists of a nominal 24-gauge, fluted exterior panel with a minimum 16" wide, 3-1/2" thick, R-13, unfaced fiberglass, insulation in panel void. A 1/2" thick sound buffer board shall separate the exterior wall system and a nominal 26-gauge, flush metal septum panel. The septum panels shall be installed perpendicular to the exterior wall panels with void filled with a minimum 16" wide, 3" thick, R-11, 4# density fibrous acoustical insulation. A vibration retardant tape will be installed between the septum panel ribs and a perforated formed liner panel. The system shall have an NRC of 1.00 and STC of 48. Wall accessories may affect overall performance.

PARTITION

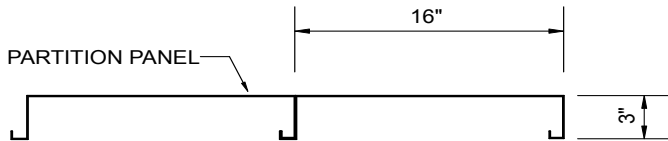

Partition system shall be 24-gauge galvanized steel interlocking panels having a factory applied embossed White color finish.

Partition panels shall be 16" wide with a 3" deep interlocking rib and include all required connecting components and anchors.

NOTE: Accessories and wall finishes available for exterior walls may be used with partitions.

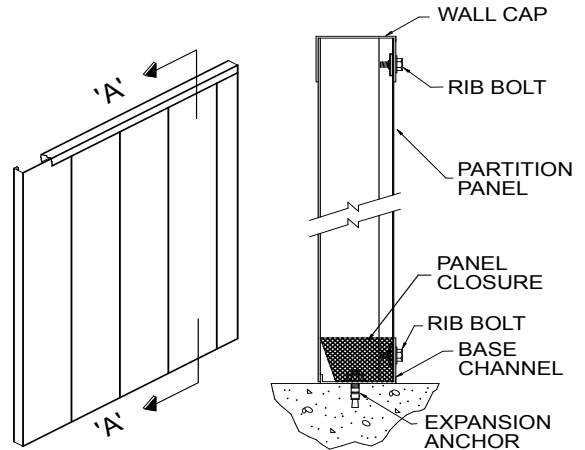

SECTION - 'A'

ROLL-IN INSULATION

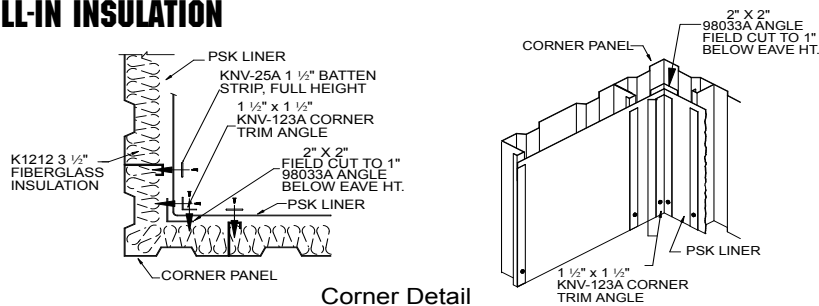

Corner Detail

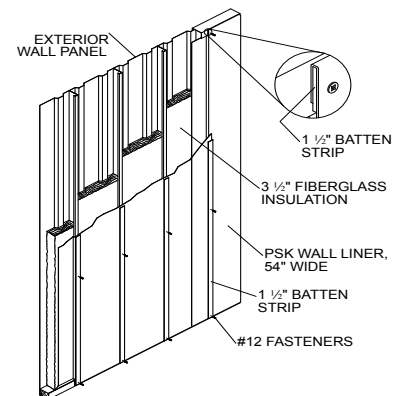

Roll-In II Insulation

The interior of the building shall be insulated with 16" wide, 3-1/2" thick R-13 unfaced fiberglass insulation with separate white metal-polypropylene scrimkraft facing stretched across the interlocking panel ribs and held in place with a white PVC 1-1/2" wide batten strip attached with #12 self drilling fasteners.

Cavity Insulation	R 13
-------------------	------

Calculated system "U" value 0.19 (ASHRAE zone method)

PANL-LINE BUILDING SYSTEM



EXPERIENCE

As the worldwide leader in building systems construction, Butler takes your building needs very seriously. We know that you will benefit significantly from a building that performs superbly and looks great for many, many years. Quality and value count.

We take great pride in providing each Panl-Line™ building according to three key words — Quality, Innovation and Reliability. We develop differences that matter to you as the building owner.

You'll often hear us refer to our unique product advantages as "The Butler Difference." We invite you to discover what this difference can mean for you regarding small buildings.

ATTRACTIVE

Panl-Line buildings give you long-life Galvalume® standing seam roof systems, concealed fastener interlocking walls and a wide choice of integrated accessories and interior finishes.

ENERGY EFFICIENT

Panl-Line buildings offer a wide variety of roof and wall insulation systems to minimize life cycle heating and cooling costs.

FLEXIBLE

Panl-Line buildings give you a large selection of widths, lengths and heights in two different building types. The 16" panel system permits precise location of the building's accessories and factory cut openings.

DURABLE

Heavy gauge roof (18–24 ga) and walls (24 ga), long life panel finishes and high quality accessories give you the best solution to your small building needs.

ONLY FROM YOUR BUTLER BUILDER®

Your Butler Builder® offers complete construction services with single-source responsibility, knowledge of local building codes and a reputable track record. Find your local Butler Builder at www.butlerbuilder.com.



Butler Manufacturing
Kansas City, MO

Butler Buildings Canada
Burlington, ON
Canada L7M 3X1

www.butlermfg.com



Galvalume® is a registered trademark of BIEC International, Inc. Thermax™ is a trademark of The Dow Chemical Company ("Dow") or an affiliated company of Dow. Kynar 500® is a registered trademark of Arkema. Hylar 5000® is a registered trademark of Solvay Solexis.

Butler building products are constantly being improved, therefore, the information contained herein is subject to change without notice. Before finalizing project details, contact your nearest Butler Builder® or Butler Manufacturing for the latest information.

Contact your Panl-Line Specialist at (304) 586-0979.